

# P862

P862 is an LED luminaire that excels in optical performance, thermal management, compatibility and serviceability, resulting in an uncompromised outcome of efficiency and versatility that is future-proofed for an optimised investment.

P862 has been designed to meet most demanding lighting requirements, being easy to install and maintain. It combines the latest LED light source with state-of-the-art design, achieving longevity for both LEDs and the drivers. The installation is simple and fast, and the luminaire is easily upgradable on-site if required.

P862 is the ultimate solution to replace traditional HID sources.

Being lightweight and having a low profile wind area enables the P862 to be safely installed on existing lighting columns and brackets.





**APPLICATIONS**

Suitable for minor and major roads

**SPECIFICATION**

Wide range of optics and lumen packages

Up to G6 glare rating

Dark sky friendly and no upward light

Advanced thermal management

Flexible and intelligent lighting control options

**CONSTRUCTION**

High pressure die-cast aluminium housing,  
Polycarbonate optic with Glass optical cover/  
lens material

**FEATURES**

- Slim and elegant aesthetics
- Future-proof and upgradable on site
- Superior luminaire efficacy up to 126 lm/W
- Wide range of optics and lumen packages
- Advanced thermal management
- Maximised savings on energy and maintenance costs
- Contractor-friendly installation and maintenance
- Minimal total cost of ownership
- Up to ME2 lighting class applications
- Flexible and intelligent lighting control options
- Low windage and lightweight
- IP66 ingress protection
- 100% recyclable

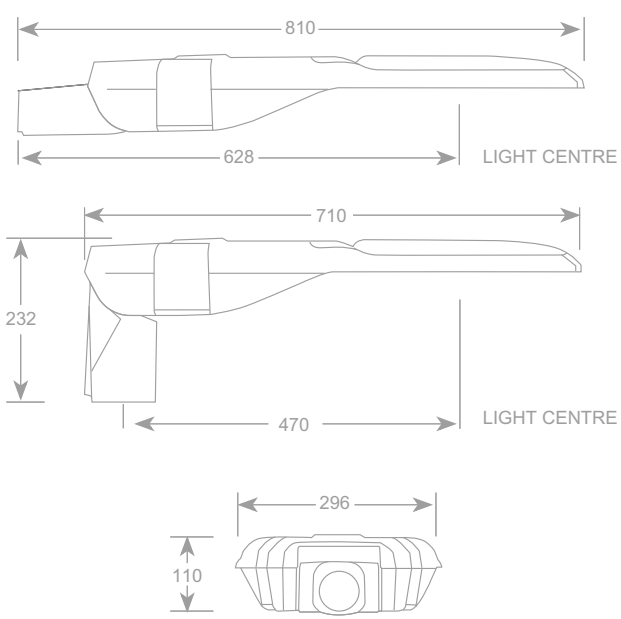

<p>CLASS 1</p>	<p>VANDAL PROOF IK09</p>	<p>WATER &amp; DUST IP66</p>	<p>LED</p>
<p>LIFE 100000 hrs Lamp Life</p>	<p>WEIGHT 8.5- 9.7Kg</p>	<p>WINDAGE 0.042m²</p>	